

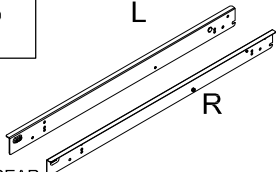

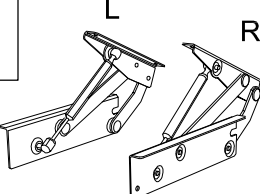
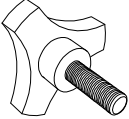
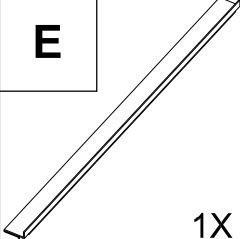
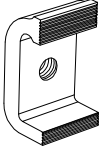
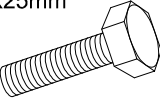
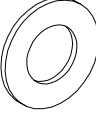
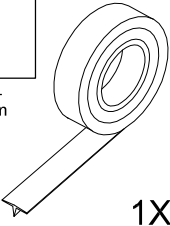
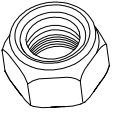

# INSTALLATION INSTRUCTIONS (K134) Isuzu-RT50 D Max-2012-Double Cab-Sportlid I

<b>A</b>  1X	<b>B</b>  REAR 1X	<b>C</b>  L R 1X	<b>D</b>  2X		
<b>E</b>  1X	<b>F</b>  2X	<b>G</b>  M8x25mm 2X	<b>H</b>  M8x16mm 8X	<b>I</b>  T-SEAL 1700mm 1X	<b>J</b>  M8 Nylock 4X
<b>K</b>  M8 Stainless Steel Spring Washer 2X	<b>L</b>  2X	<b>M</b>  2X	<p><b>Note 1:</b> If at any stage of installation you find your sportlid to be an unacceptable fit please contact the manufacturer before continuing.</p> <p><b>Note 2:</b> If required, use Under Rail Bed Liner only. Not for use with Over Rail Bed Liner</p> <p><b>Tools Required:</b> 4mm Allen key, 13mm Wrench, 14mm Wrench</p>		

**RAIN SEAL MUST BE APPLIED AFTER PAINT PROCESS IS COMPLETE**

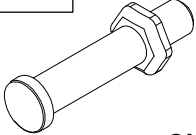
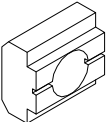
**!** DO NOT apply below 15°C.  
DO NOT stretch when applying.  
Apply pressure to seal. Adhesive is pressure activated.  
Allow 3hrs minimum to cure before fitting lid.

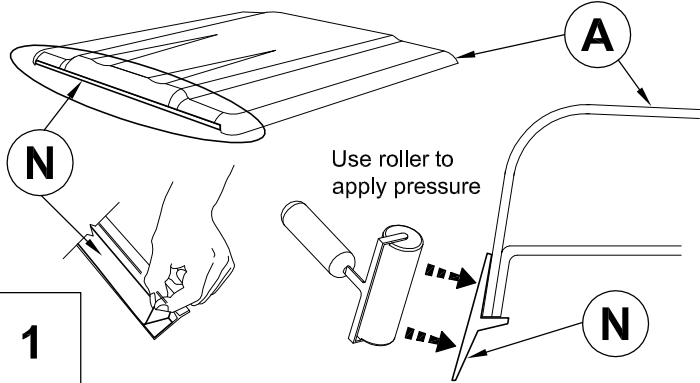

1

Remove ladder rack

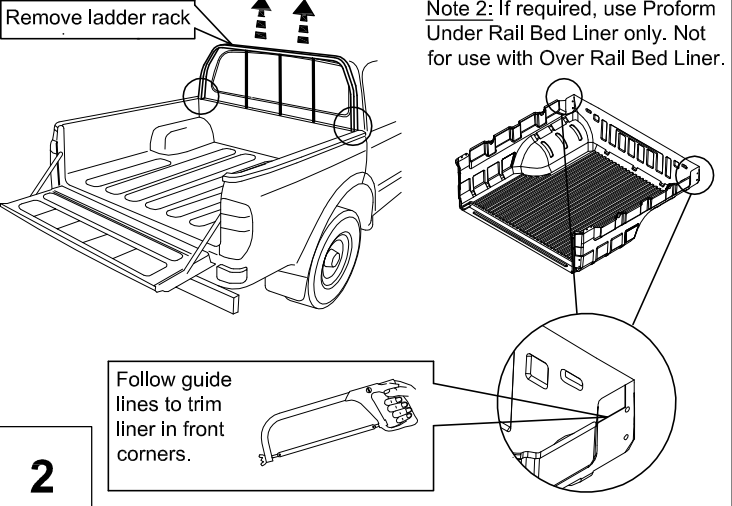

2

Note 2: If required, use Proform Under Rail Bed Liner only. Not for use with Over Rail Bed Liner.

Follow guide lines to trim liner in front corners.

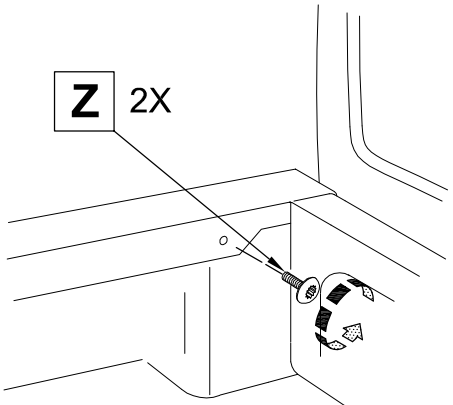

3

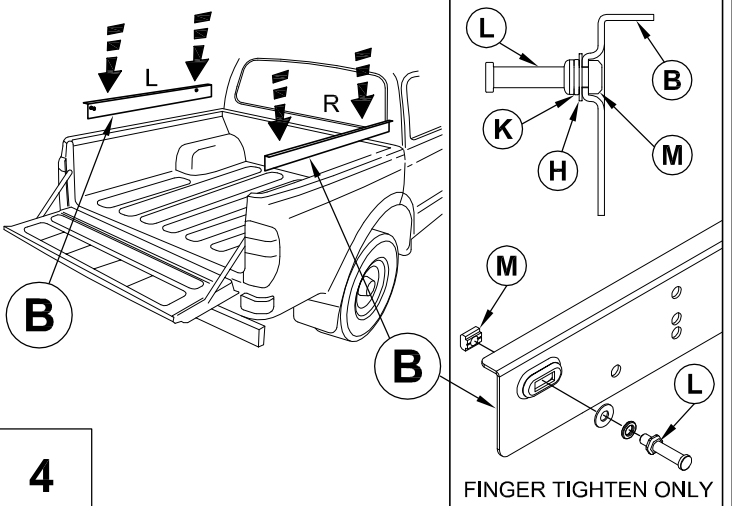

4

FINGER TIGHTEN ONLY

Fitting Kit Number	Manufacturer	Model Type	Year	Stockist	Cab Size	Product	Revision	Date	Page
IDFK134	Isuzu	RT50 D Max	2012	General Use	DC	Sportlid 1	1	5-06-12	1 of 3

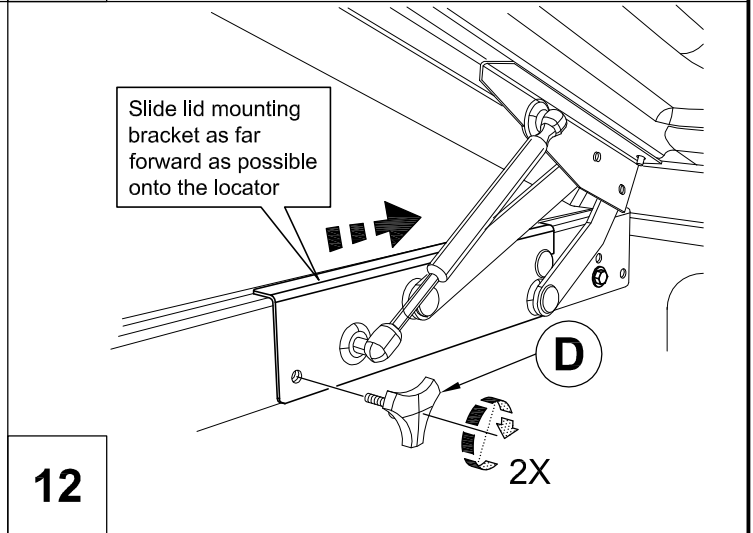
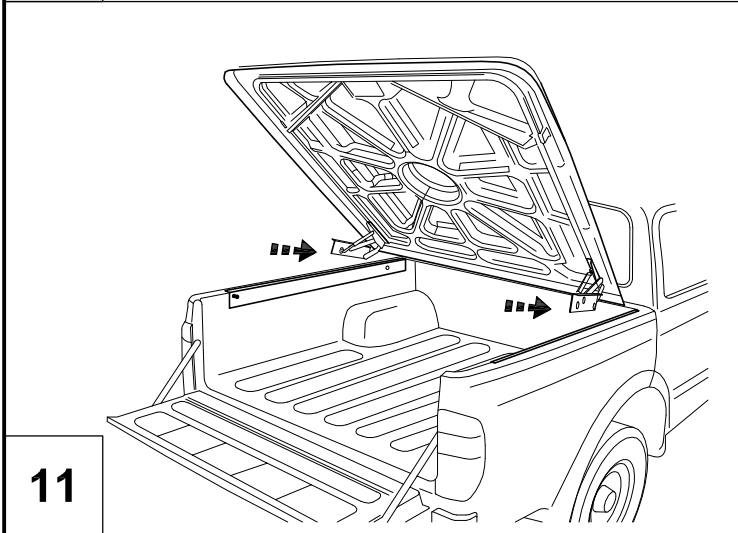
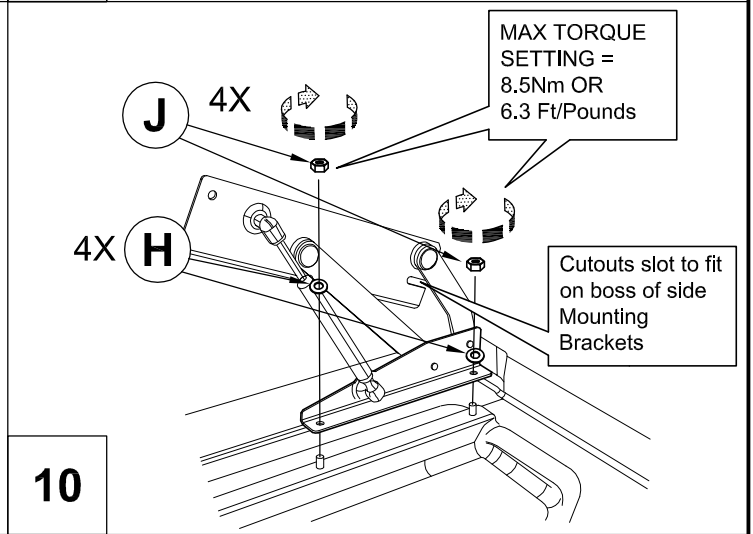
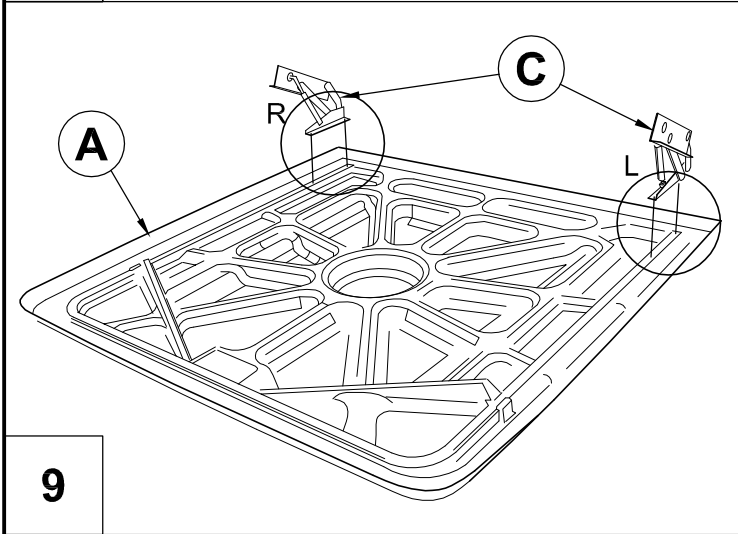
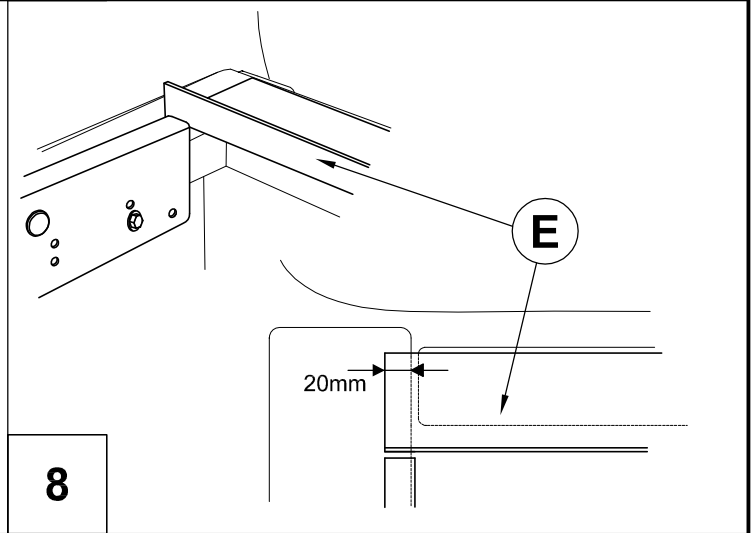
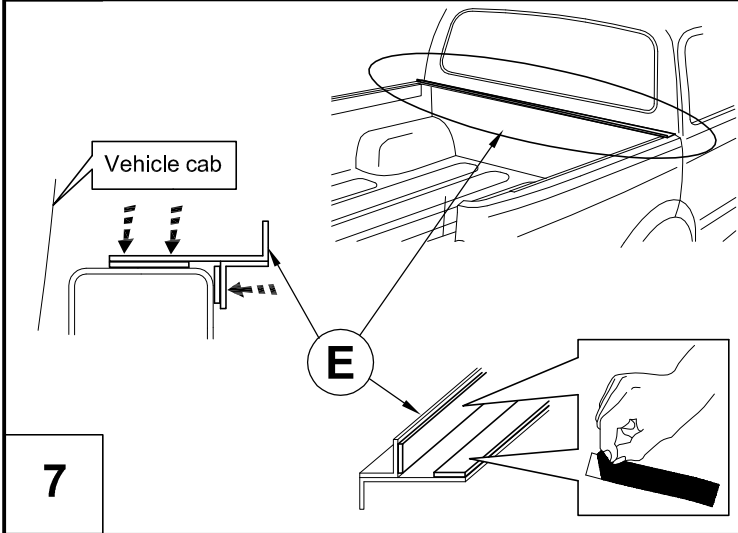
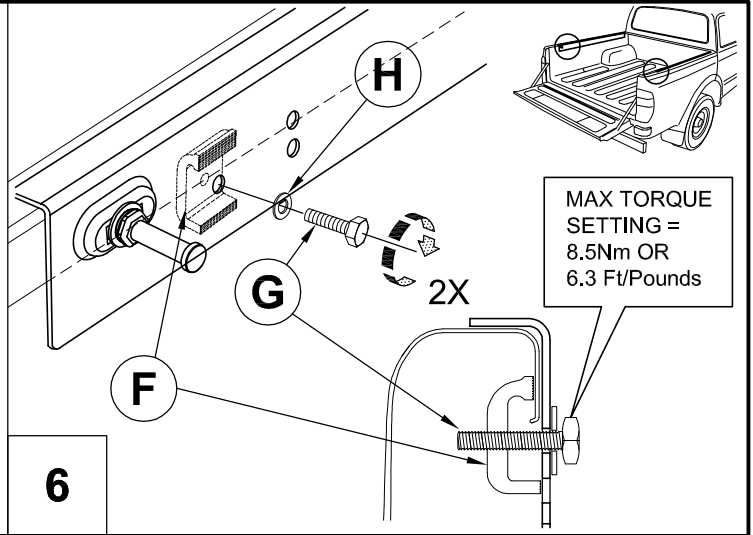
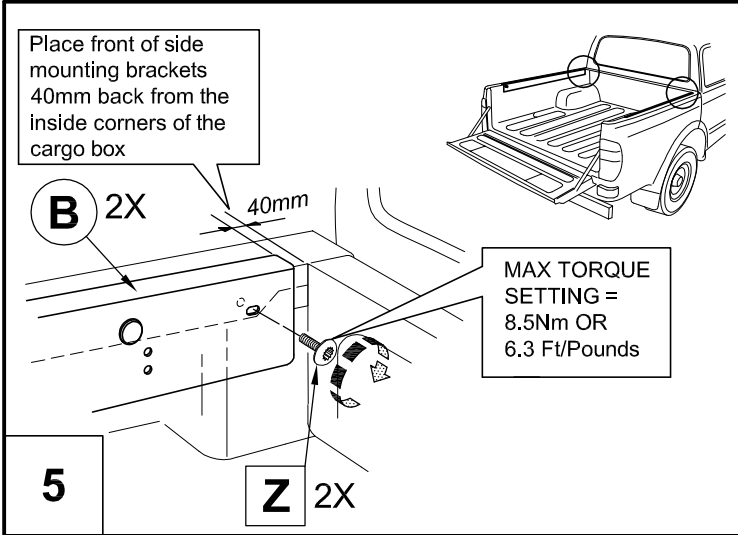

Fitting Kit Number	Manufacturer	Model Type	Year	Stockist	Cab Size	Product	Revision	Date	Page
IDFK134	Isuzu	RT 50 D Max	2012	General Use	DC	Sportlid 1	1	5-06-12	2 of 3

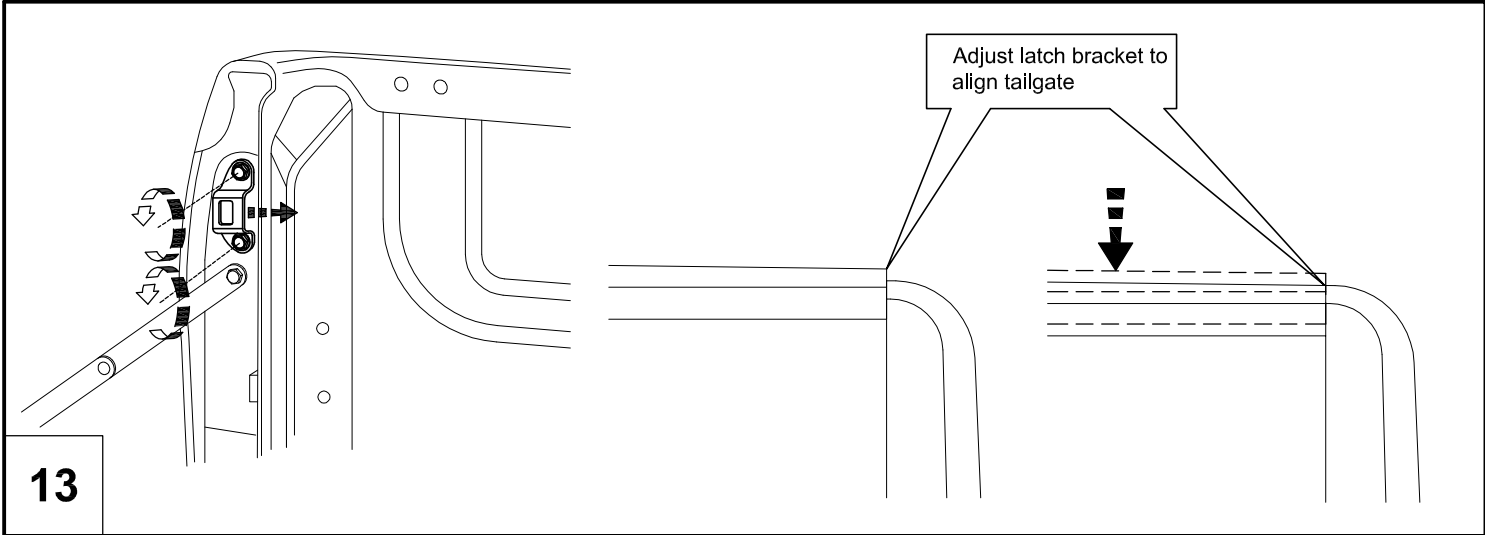

13

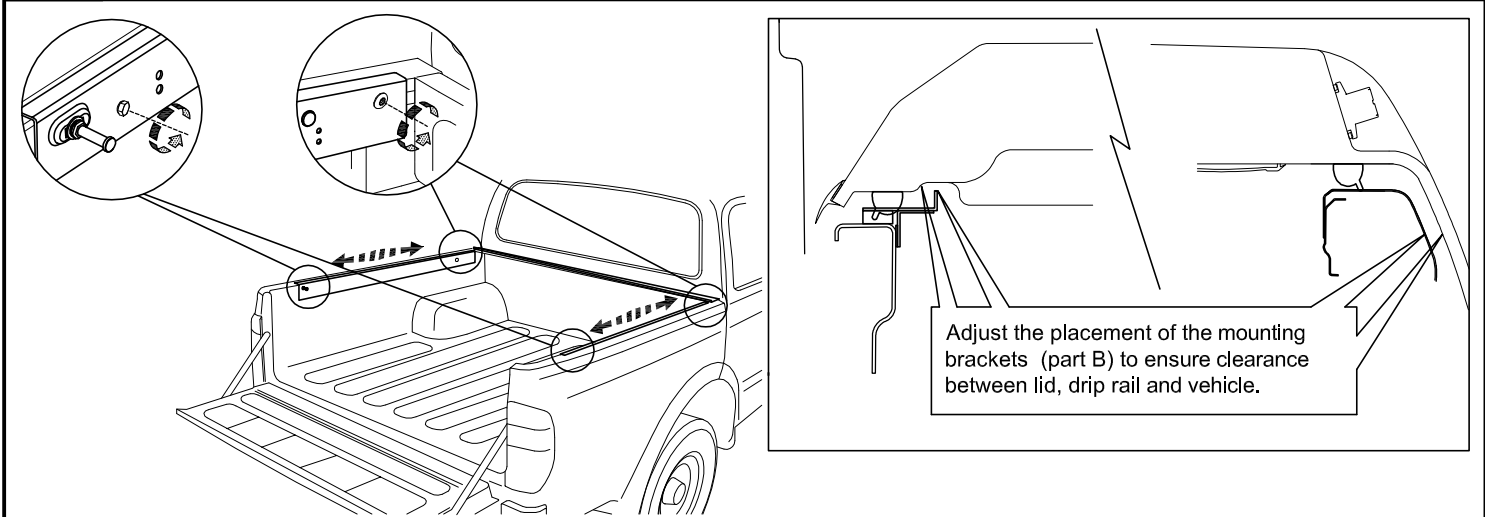

14

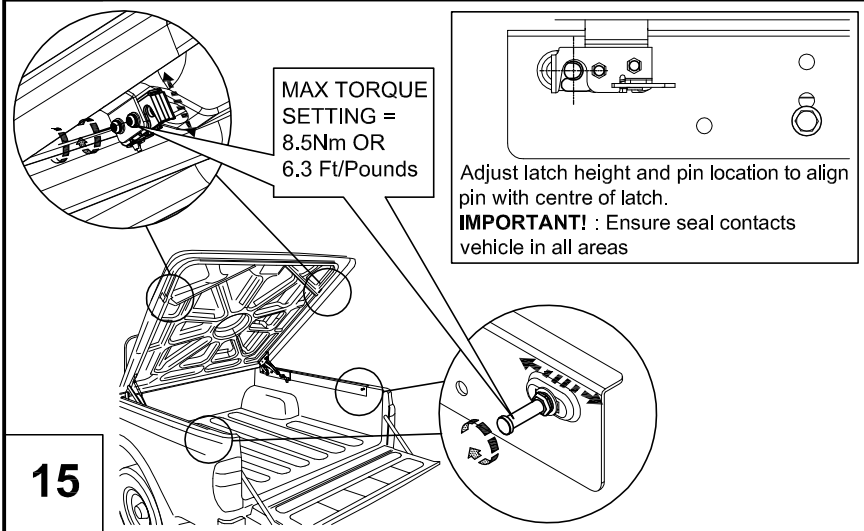
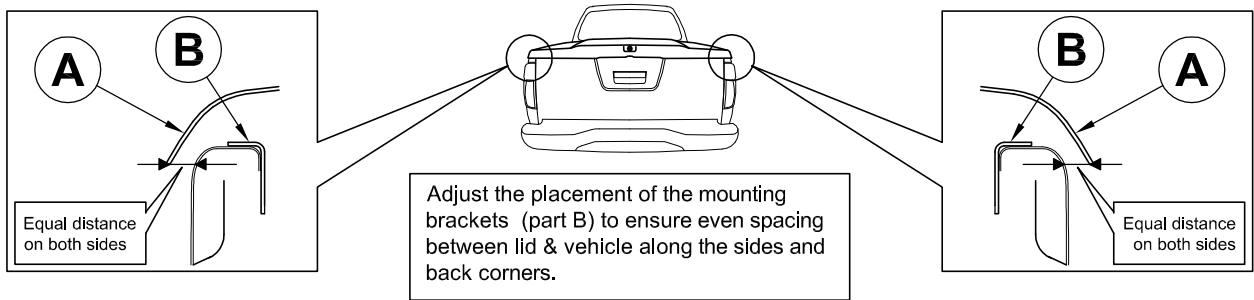

15

After required clearances and alignment is achieved, tighten all bolts to torque settings stated.

Retain these instructions for reference.

Fitting Kit Number	Manufacturer	Model Type	Year	Stockist	Cab Size	Product	Revision	Date	Page
IDFK134	Isuzu	RT 50 D Max	2012	General Use	DC	Sportlid 1	1	5-06-12	3 of 3